

Control units MAGTRONIC

MUB

MUB Control Equipment

The MUB microprocessor control unit can be used with all Magnetic barriers MSV/MTS 6/8 with manual or automatic operation. The barrier is opened and closed by use of special operator panels, or a customer installed pulse generator with potential free contacts. For external equipment, there is a 24 Volt DC supply with a maximum 0,2 Amp. output. Triac switching of the barrier motor provides maintenance-free service.

Technical

The complete controller is contained in an isolated plastic housing. If required, rapid and easy replacement is possible by means of two removeable terminal strips on a standard mounting rail. Three rotary switches located on the top panel control the mode (function) setting, the torque time (max. 15 seconds) and the hold-open-time (max. 75 seconds). The indication of the active signal entries, barrier boom position (up/down) and the torque operation is achieved through built in LED's.

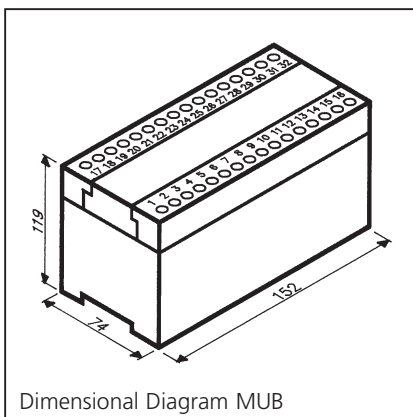

Functions

The factory sets the mode (function) by the customer's requirements. By turning the rotary-switches this function may be changed at a later date.

After every power failure, or every function change, it is recommended to „RESET“.

Mode 1:
(Maintained contact function 100)
The barrier is controlled by a potential-free switch. Contact closed = barrier „closed“.

Mode 2:
(Dead man function 200)
To open the barrier, merely press the key „open“. The key „close“ must be operated until the barrier has reached its lowest limit. If the key is released prior to this, the barrier will open again.
For the feedback of the position „closed“ a limit switch is necessary (terminal 19 and 23).

Mode 3:
(Pulse control function 300)
The barrier position is controlled by pulses from a push-button. Each pulse results in a directional change (up/down) of the barrier boom.

Mode 4:
(Pulse control function 350)
The barrier position is controlled by pulses from two separate push-buttons. One for „up“ and one for „down“.

Mode 5:
(Dynamic function 400)
The barrier is opened by a pulse and closes automatically after an adjustable hold-open-time or immediately after the safety device has been passed or after a closing pulse has been given. As safety device an induction loop for example must be installed under the barrier boom. Closing is prevented as long as a vehicle is positioned in the detection area.

Mode 6:
(Same function as mode 5)
When using a safety loop and an opening loop the loops are detecting the direction of the traffic, i. e. the barrier closes immediately after the safety loop has been passed.

Mode 7:
(Static function 500)
Like mode 5 function 400, but without automatic closing after a specified hold-

open-time. The barrier remains open until a vehicle has activated the safety device and only closes after it has left the detection area.

Mode 8:
(Same function as mode 7 with additional detection of direction, see mode 6.)

Detection

If a vehicle is in the barrier boom area, closing can be prevented by connection of the safety loop detection system to the terminal 19 and 24. (Normally closed contact.)
The detector MID 1A-100 is recommended for use with induction loops that are installed in the ground.
In the event that no detection is desired a wire bridge must be connected between terminals 19 and 24.

Electronic Braking

To increase the lifetime of the mechanism of a barrier with short opening and closing times of under 2 seconds, an electronic braking action can be applied just prior to reaching the end position of the up and down actions. A braking limit switch with two trip cams is required (terminal 19 and 23).
The braking function is not possible in Mode 2 (Deadman).

Count Pulse

A potential-free pulse (300 ms) is given to terminals 31 and 32, after a vehicle opens and passes the closing detection device.

Connection

All connections can be made to the externally mounted terminal strips. All function inputs and status signals operate at a safe voltage level and are separated by optocouplers. The connections for the motor and capacitors carry a 230 Volt potential.

